

EXPLODED DIAGRAM OF CS80.16

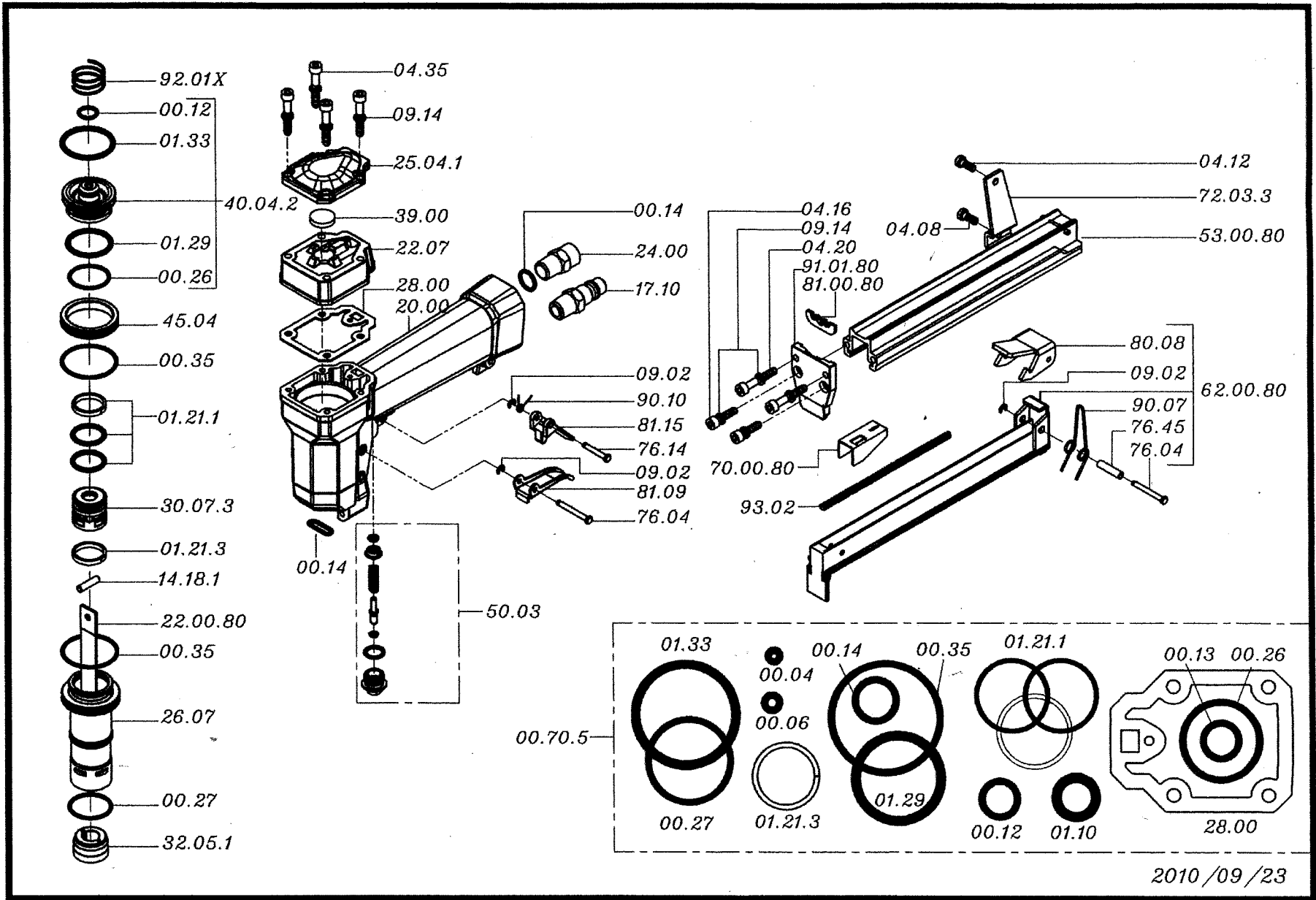

PART LIST OF 80.16

No.	Code.	Description	unit	No.	Code.	Description	unit
1	00.12	O-Ring	1	25	30.07.3	Piston	1
2	00.14	O-Ring	3	26	32.05	Bumper	1
3	00.26	O-Ring	1	27	39.00	Exhaust gasket	1
4	00.27	O-Ring	1	28	40.04.2	Valve ass'y.	1
5	00.35	O-Ring	2	29	45.04	Ring	1
6	01.21.1	Gasket	1	30	50.03	Trigger Valve Assembly	1
7	01.21.3	Gasket	1	31	72.03.3	Support	1
8	01.29	O-Ring	1	32	76.04	Pin	2
9	01.33	O-Ring	1	33	76.14	Pin	1
10	04.08	Screw	1	34	76.45	Pin	1
11	04.12	Screw	1	35	80.08	Trigger	1
12	04.16	Screw	2	36	81.09	Trigger	1
13	04.20	Screw	2	37	81.15	Safety	1
14	04.35	Screw	4	38	90.07	Spring	1
15	09.02	Elastic Ring	3	39	90.10	Spring	1
16	09.14	Washer	8	40	92.01X	Spring	1
17	14.18.1	Pin	1	41	93.02	Spring	1
18	17.10	Air Plug 1/4"	1	42	22.00.80	Driver	1
19	20.00	Body	1	43	53.00.80	Slider	1
20	22.07	Head	1	44	62.00.80	Magazine	1
21	24.00	Silencer	1	45	70.00.80	Pusher	1
22	25.04.1	Exhaust deflector	1	46	81.00.80	Nose	1
23	26.07	Cylinder	1	47	91.01.80	Nose Plate	1
24	28.00	Gasket	1	48	00.70.5	O-Ring Kit	1

2007/11/14